

PREVIEW

Capacity 300 kg
(3 persons 80x3=240 kg
+ toolbox 60 kg)

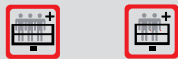
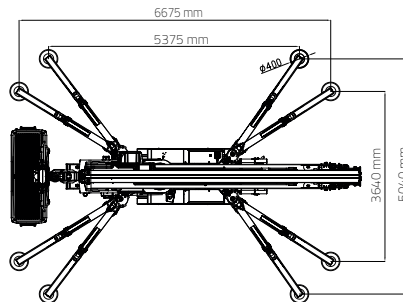
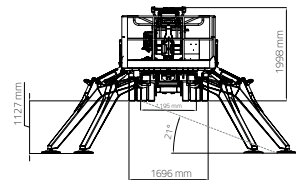
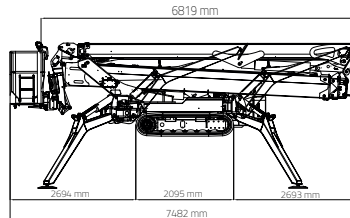

Bi-energy
(Diesel + Lithium-ion battery pack)

- 40,20 m
- 16,50 m 17,5 m
- 7,50 m
- 6,82 m
- 1,99 m

- 1196 - 1696 mm
- 2000x700xH1100mm
- 5375x5040 mm (total)
6675x3640 mm (reduced)
- 8.700 kg / 19.181 lb (Diesel)
8.800 kg / 19.401 lb (Lithium)
9.000 kg / 19.842 lb (Bi-energy)
- KUBOTA D902 - 21,6HP/3200rpm
- 380V / 50 Hz - 11 kW

- Lithium-ion battery pack
19,2 kW/h
- Automatic set up system
IIIS std
- Remote control
- GPRS-GPS
- R.A.H.M.

Hinowa is continually researching and developing products and reserves the right to make modifications without prior notice. All data in this document is indicative. Certain options or country standards will increase weight. Specifications may change to meet country standards or with the addition of optional equipment.