



CE MODELS | SJIII 3220 SJIII 3226



CONVENTIONAL SERIES DC Electric SCISSOR LIFTS

The Narrow Conventional Series DC Electric Scissor Lifts offer high capacity and large platform areas, making them suitable for any on-slab application. Featuring variable speed rear wheel hydraulic drive, the SJIII 3220 and SJIII 3226 offer working heights up to 9,9 m and 25% gradeability.

The lightest machines in their class, these models offer a standard 0,9 m roll out extension deck, and both models can be driven at full height. The SJIII 3220, boasting an industry leading 408 kg capacity, can also access through standard doorways.

Consistent with Skyjack's robust and reliable design features, the Narrow Conventional Series DC Electric Scissor Lifts utilize Skyjack's standard colour coded and numbered wiring system with analog based controls.



CONVENTIONAL SERIES

DC Electric Scissor Lifts

Specifications	SJIII 3220	SJIII 3226
A Work Height	8,1 m	9,9 m
B Raised Platform Height	6,1 m	7,9 m
C Lowered Platform Height	1,0 m	1,1 m
D Overall Width	0,8 m	0,8 m
E Overall Length	2,3 m	2,3 m
F Stowed Height (Rails Up)	2,0 m	2,2 m
G Stowed Height (Rails Down)	1,6 m	1,8 m
H Platform Width (Inside Dimension)	0,7 m	0,7 m
I Platform Length (Inside Dimension)	2,1 m	2,1 m
Extension Deck (Roll Out)	0,9 m	0,9 m
Ground Clearance (Stowed)	8,9 cm	8,9 cm
Ground Clearance (raised)	1,9 cm	1,9 cm
Wheelbase	1,8 m	1,8 m
Weight	1592 kg	1876 kg
Gradeability	25%	25%
Turning Radius (Inside)	1,3 m	1,3 m
Turning Radius (Outside)	2,7 m	2,7 m
Lift Time (With Rated Load)	33 sec	56 sec
Drive Speed (Stowed)	3,2 km/h	3,2 km/h
Drive Speed (Raised)	1,1 km/h	1,1 km/h
Maximum Drive Height	Full Height	Full Height
Capacity (Overall)	408 kg	227 kg
Maximum # of Persons	2	2

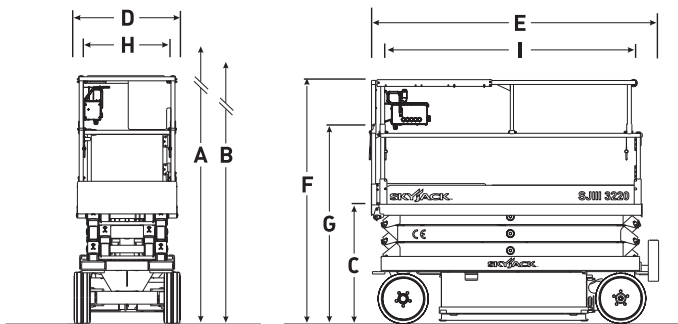

STANDARD FEATURES

- Drivable at full height
- Variable speed, rear two wheel hydraulic drive
- Dual holding brakes
- Proportional controls for drive & lift functions
- 0,9 m roll out extension deck
- 24V DC power source
- Low voltage battery protection
- Analog control system
- Colour coded and numbered wiring system
- 25% gradeability
- Solid rubber, non-marking tyres
- Pothole protection system
- Wiring for AC outlet on platform
- Tilt alarm with drive & lift cut-out
- All motion audible alarm
- Overload sensing system
- Lowering warning system
- Operator horn
- Hinged railing system (3226 only)
- Half height spring hinged gate
- Lanyard attachment points
- Forklift pockets and tie down/lift lugs

OPTIONS†

- Flashing light
- 1,83 m powered extension deck (3220 only)
- Shop airline to platform
- 0.8 kW AC inverter
- 250 Ah batteries
- Hinged railing system (3220 only)
- Full height spring hinged gate*

* Not available with hinged railing system on 32xx's

† Capacities, and machine weights may differ when options are added

Skyjack UK

Unit 1, Maes-y-Clawdd
 Maesbury Road Industrial Estate
 Oswestry, Shropshire, SY10 8NN
 Phone: +44-1691-676235
 Fax: +44-1691-676239
 Email: info@skyjackeurope.co.uk

www.skyjack.com

This brochure is for illustrative purpose only and based on the latest information at the time of printing. Skyjack Inc. reserves the right to make changes at any time, without notice, to specifications, standard and optional equipment. Consult the Operating Maintenance and Parts Manuals for proper procedures. CE marked work platforms are in conformance to the Machinery Directive 98/37/EC.