

HS701 CONSTRUCTION VERSION

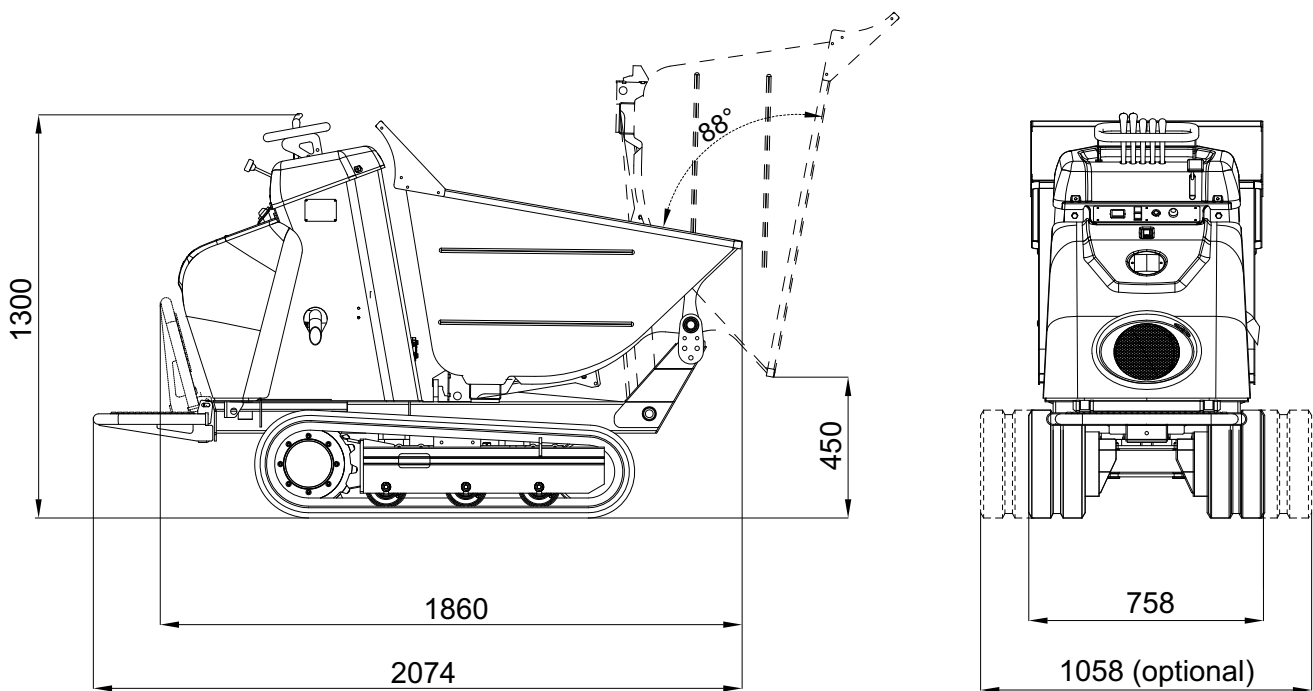

HS701

CONSTRUCTION VERSION

PETROL ENGINE

Brand and type.....Honda GX270
Pistons and displacement.....single-cylinder 270 cc
Max gross power.....8,4 HP - 6,3 kW @ 3600 rpm
Startingmanual
Fuel tank5,3 liters
Granted noise levelLwa 99 dB

DIESEL ENGINE

Brand and type.....KUBOTA OC 95
Pistons and displacement.....single-cylinder 416 cc
Max gross power.....9,4 HP - 7,0 kW @ 3600 rpm
Startingelectric 12 volt
Fuel tank5,5 liters
Granted noise levelLwa 101 dB

DISTRIBUTOR

Type mechanical

HYDRAULIC PUMPS

Number and typen° 3 gear pumps

TRACKS

Track tensioner.....grease
Track width180 mm
Rollers per side3
Undercarriage width open/close758 - 1058 mm

PERFORMANCE

Translation speed petrol engine2,2 - 3,3 km/h
Translation speed diesel engine2,2 - 3,3 km/h
Max. inclination20° (diesel version)

CAPACITY..... 700 kg

DUMPER BED CAPACITY

Rated volume (ISO 6483)0,34 m³
Struck volume0,28 m³

OPERATING WEIGHT (without operator)

Fixed/widening undercarriage - petrol engine.....540 kg / 620 kg
Fixed/widening undercarriage - diesel engine.....580 kg / 660 kg

HS701 SELF LOADING VERSION

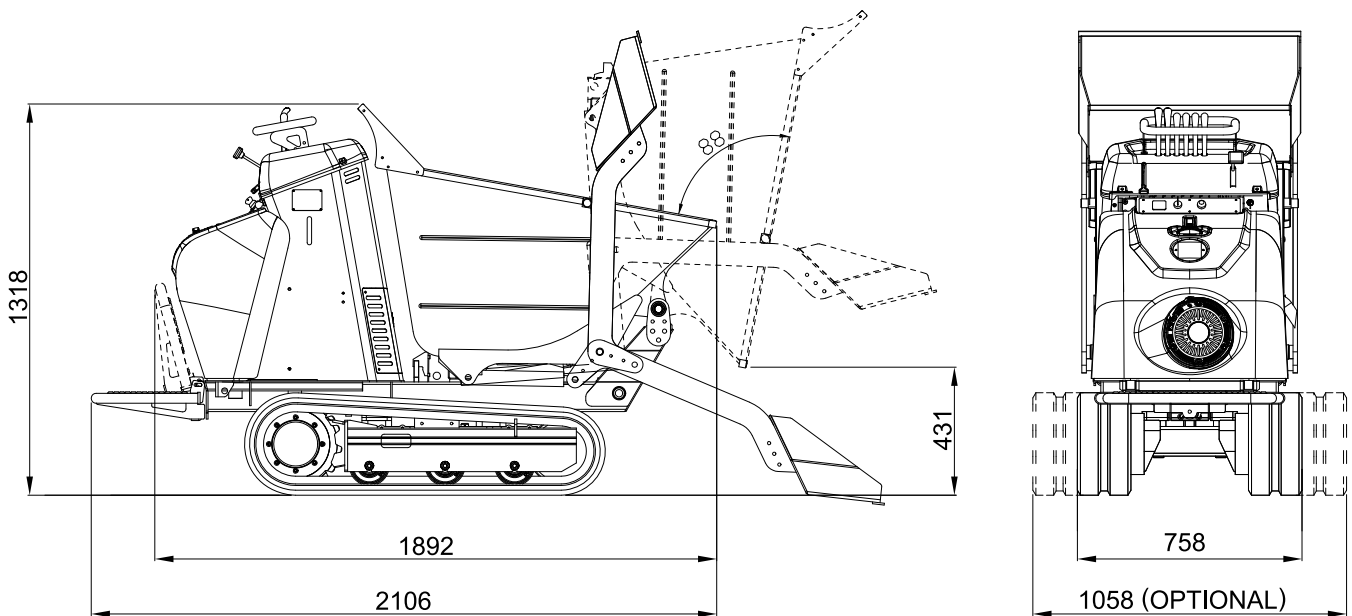

HS701

SELF LOADING VERSION

PETROL ENGINE

| | |
|--------------------------------|---|
| Brand and type | Honda GX270 - GX390 |
| Pistons and displacement | single-cylinder 270 cc (GX270) - 389 cc (GX390) |
| Max gross power | 8,4 HP - 6,3 kW@3600rpm (GX270) |
| | 11,7 HP - 8,7 kW@3600rpm (GX390) |
| Starting | manual (GX270) - electric (GX390) |
| Fuel tank | 5,3 liters (GX270) - 6,1 liters (GX390) |
| Granted noise level | Lwa 99 dB |

DIESEL ENGINE

| | |
|--------------------------------|----------------------------|
| Brand and type..... | KUBOTA OC 95 |
| Pistons and displacement | monocilindrico da 416 cc |
| Max gross power | 9,4 HP - 7,0 kW @ 3600 rpm |
| Starting | electric 12 volt |
| Fuel tank | 5,5 liters |
| Granted noise level | Lwa 101 dB |

DISTRIBUTOR

| | |
|------------|------------|
| Type | mechanical |
|------------|------------|

HYDRAULIC PUMPS

| | |
|-----------------------|-----------------|
| Number and type | n° 3 gear pumps |
|-----------------------|-----------------|

TRACKS

| | |
|--------------------------------------|---------------|
| Track tensioner..... | grease |
| Track width | 180 mm |
| Rollers per side | 3 |
| Undercarriage width open/close | 758 - 1058 mm |

PERFORMANCE

| | |
|---------------------------------------|------------------------|
| Translation speed petrol engine | 2,2 - 3,3 km/h (GX270) |
| | 2,8 - 4 km/h (GX390) |
| Translation speed diesel engine | 2,2 - 3,3 km/h |
| Max. inclination | 15° (diesel version) |

| | |
|-----------------------|--------|
| CAPACITY | 700 kg |
|-----------------------|--------|

DUMPER BED CAPACITY

| | |
|-------------------------------|---------------------|
| Rated volume (ISO 6483) | 0,34 m ³ |
| Struck volume | 0,28 m ³ |

OPERATING WEIGHT (without operator)

| | |
|--|-----------------|
| Fixed/widening undercarriage - petrol engine GX270 | 600 kg / 680 kg |
| Fixed/widening undercarriage - petrol engine GX390 | 640 kg / 720 kg |
| Fixed/widening undercarriage - diesel engine..... | 655 kg / 735 kg |

HS701 HIGH-TIP DUMPER BED

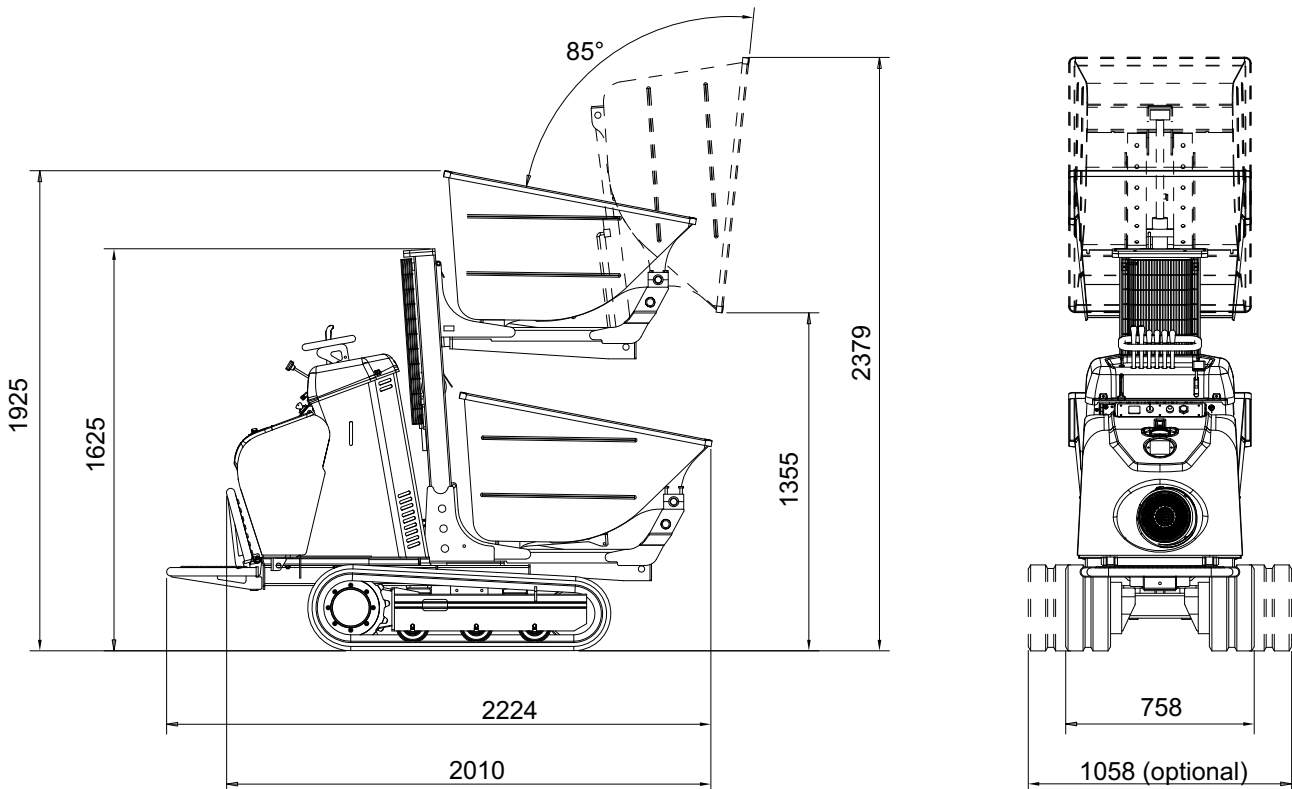

HS701 HIGH-TIP DUMPER BED

PETROL ENGINE

Brand and type.....Honda GX270
 Pistons and displacementsingle-cylinder 270 cc
 Max gross power8,4 HP - 6,3 kW @ 3600 rpm
 Starting.....electric 12 volt
 Fuel tank5,3 liters
 Granted noise levelLwa 99 dB

DIESEL ENGINE

Brand and type.....KUBOTA OC 95
 Pistons and displacementsingle-cylinder 416 cc
 Max gross power9,4 HP - 7,0 kW @ 3600 rpm
 Starting.....electric 12 volt
 Fuel tank5,5 liters
 Granted noise levelLwa 101 dB

DISTRIBUTOR

Type mechanical

HYDRAULIC PUMPS

Number and typen° 3 gear pumps

TRACKS

Track tensioner.....grease
 Track width180 mm
 Rollers per side3
 Undercarriage width open/close758 - 1058 mm

PERFORMANCE

Translation speed petrol engine2,2 - 3,3 km/h
 Translation speed diesel engine2,2 - 3,3 km/h
 Max. inclination15° (diesel version and dumper bed lowered)

CAPACITY..... 550 kg

DUMPER BED CAPACITY

Rated volume (ISO 6483)0,29 m³
 Struck volume0,24 m³

OPERATING WEIGHT (without operator)

Fixed/widening undercarriage - petrol engine.....620 kg / 700 kg
 Fixed/widening undercarriage - diesel engine.....660 kg / 740 kg

HS701 EXTRA HIGH-TIP DUMPER BED VERSION

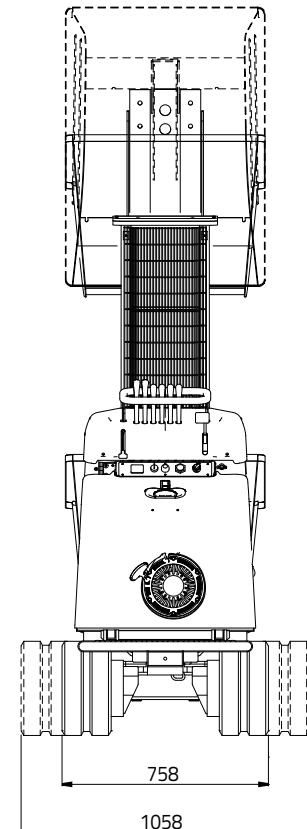
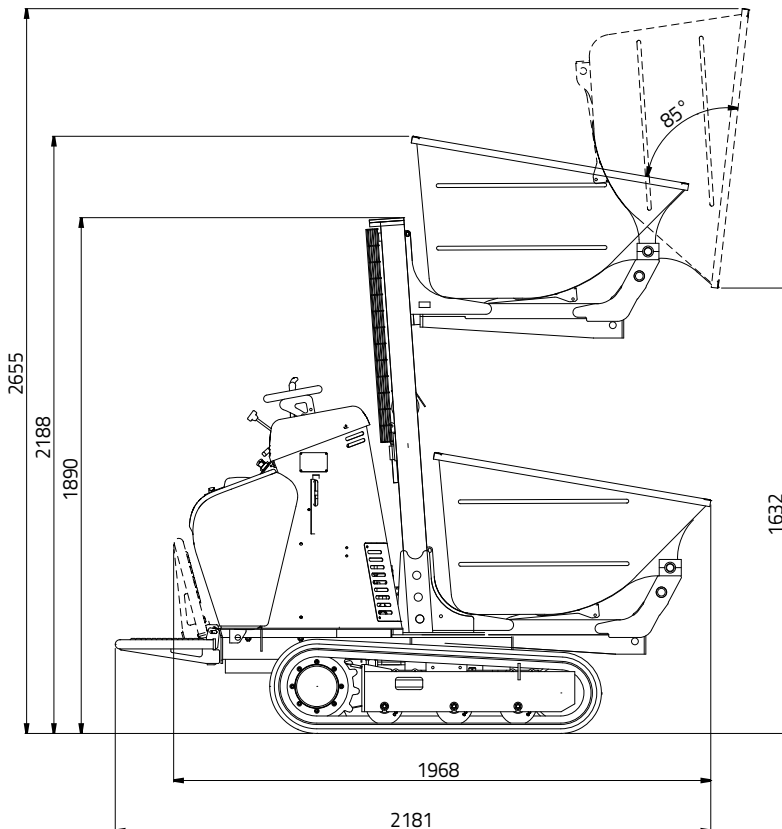

HS701

EXTRA HIGH-TIP DUMPER BED VERSION

PETROL ENGINE

| | |
|--------------------------------|----------------------------|
| Brand and type..... | Honda GX270 |
| Pistons and displacement | single-cylinder 270 cc |
| Max gross power | 8,4 HP - 6,3 kW @ 3600 rpm |
| Starting..... | electric 12 volt |
| Fuel tank | 5,3 liters |
| Granted noise level | Lwa 99 dB |

DIESEL ENGINE

| | |
|--------------------------------|----------------------------|
| Brand and type..... | KUBOTA OC 95 |
| Pistons and displacement | single-cylinder 416 cc |
| Max gross power | 9,4 HP - 7,0 kW @ 3600 rpm |
| Starting..... | electric 12 volt |
| Fuel tank | 5,5 liters |
| Granted noise level | Lwa 101 dB |

DISTRIBUTOR

| | |
|------------|------------|
| Type | mechanical |
|------------|------------|

HYDRAULIC PUMPS

| | |
|-----------------------|-----------------|
| Number and type | n° 3 gear pumps |
|-----------------------|-----------------|

TRACKS

| | |
|--------------------------------------|---------------|
| Track tensioner..... | grease |
| Track width | 180 mm |
| Rollers per side | 3 |
| Undercarriage width open/close | 758 - 1058 mm |

PERFORMANCE

| | |
|-------------------------|--------------------------|
| Translation speed | 2,2 - 3,3 km/h |
| Max. inclination | 15° (dumper bed lowered) |
| Capacity | 550 kg |

DUMPER BED CAPACITY

| | |
|-------------------------------|---------------------|
| Rated volume (ISO 6483) | 0,29 m ³ |
| Struck volume | 0,24 m ³ |

OPERATING WEIGHT (without operator)

| | |
|---------------------|--------|
| Petrol engine | 746 kg |
| Diesel engine | 800 kg |

HS701 SELF-LOADING AND EXTRA HIGH-TIP VERSION

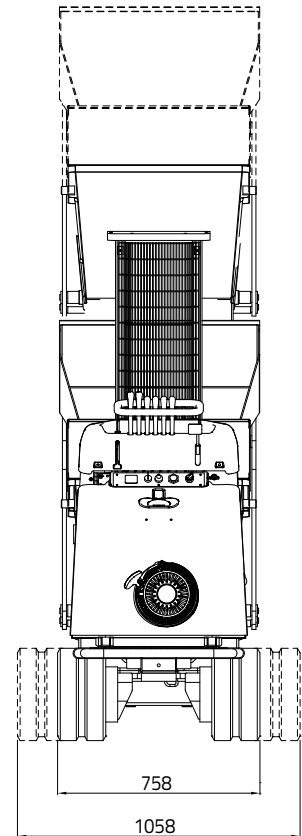
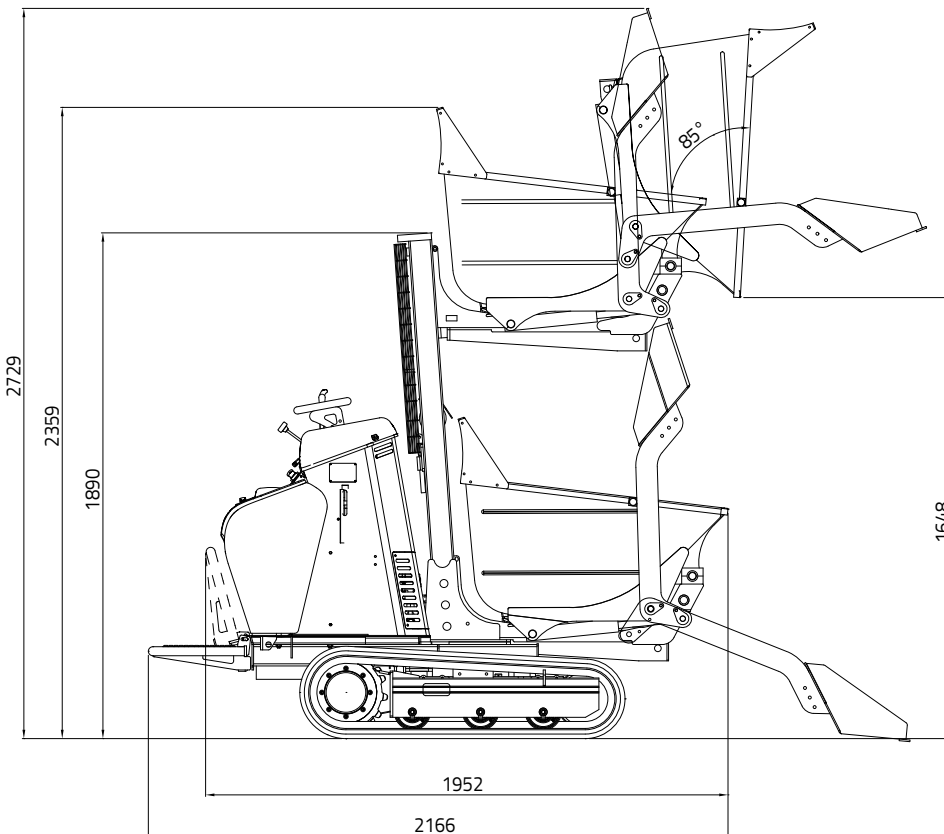

HS701

SELF-LOADING AND EXTRA HIGH-TIP VERSION

PETROL ENGINE

Brand and type.....Honda GX390
 Pistons and displacementsingle-cylinder 389 cc
 Max gross power11,7 HP - 8,7 kW @ 3600 rpm
 Startingelectric 12 volt
 Fuel tank5,3 liters
 Granted noise levelLwa 99 dB

DIESEL ENGINE

Brand and type.....KUBOTA OC 95
 Pistons and displacementsingle-cylinder 416 cc
 Max gross power9,4 HP - 7,0 kW @ 3600 rpm
 Startingelectric 12 volt
 Fuel tank5,5 liters
 Granted noise levelLwa 101 dB

DISTRIBUTOR

Type mechanical

HYDRAULIC PUMPS

Number and typen° 3 gear pumps

TRACKS

Track tensioner.....grease
 Track width180 mm
 Rollers per side3
 Undercarriage width open/close758 - 1058 mm

PERFORMANCE

Translation speed petrol engine2,8 - 4 km/h
 Translation speed diesel engine2,2 - 3,3 km/h
 Max. inclination15° (dumper bed lowered)
 Capacity460 kg

DUMPER BED CAPACITY

Rated volume (ISO 6483)0,25 m³
 Struck volume0,19 m³

OPERATING WEIGHT (without operator)

Petrol engine852 kg
 Diesel engine876 kg