

# All Terrain Platform

**UpRight**  
POWERED ACCESS



- 16.8m max. working height
- 7.9m max. outreach
- Two person, 215kg capacity platform
- 1.4m, 140° jib
- Levelling outriggers
- 90° powered platform rotation
- 4 wheel drive and high grip tyres
- 40% gradeability
- 22 kmh drive speed

**AB48  
HSRT**



# AB48HSRT all terrain platform specifications

## AB48HSRT ALL TERRAIN

max. working height	16.8m
max. platform height	14.8m
max. outreach	7.9m
platform capacity (SWL)	215kg
outrigger footprint	2.40m(A) x 3.60m(B)
turret rotation (non-continuous)	90°
platform rotation	90°
platform depth C	0.80m
platform width D	1.20m
travel height E	2.75m
travel length F	6.10m
travel width G	1.90m
gross weight	3500kg
control system	fully proportional hydraulic controls at ground and basket
power source	Engine: twin cylinder, water cooled, 32HP complete with hydrostatic 4 wheel drive

Specifications subject to change without notice. Photos and diagrams in this brochure are for promotional purposes only. Refer to appropriate UpRight operators manual for detailed instructions on the proper use and maintenance.

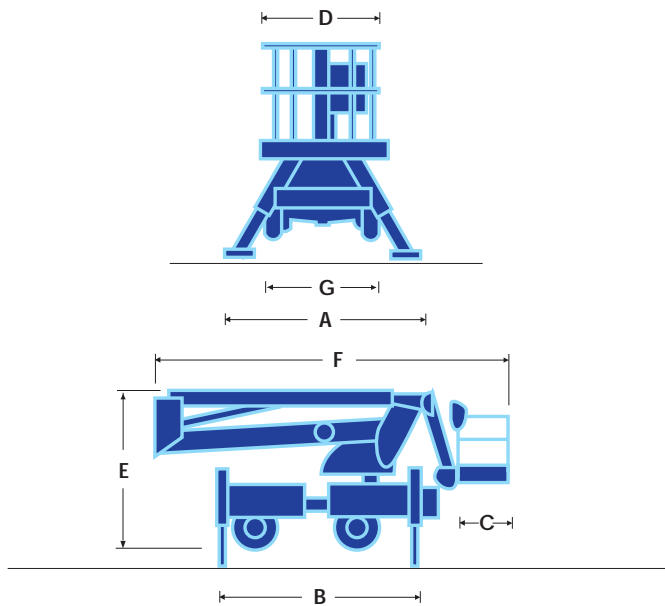

BP1 - AB48HSRT 10/06

**UpRight**  
POWERED ACCESS

Vigo Centre, Birtley Road, Washington,  
Tyne & Wear, NE38 9DA, U.K.

Sales Tel: +44 (0) 845 1550 057 • Spare Parts Tel: +44 (0) 845 1550 058

[www.upright.com](http://www.upright.com)

## standard features

- Articulating / telescopic boom with 1.4m, 140° jib
- 3500kg gross weight
- 90° hydraulically powered platform rotation
- Hand pump emergency lowering from platform
- Lock valves on all hydraulic cylinders
- Proportional live hydraulic controls
- 32 HP two cylinder diesel engine
- Permanent hydrostatic 4 wheel drive
- 4 forward and 4 reverse gears
- 1 year parts and labour warranty
- 5 year structural warranty

## options

- Flotation tyres and larger outrigger feet
- 12V auxiliary battery power
- Hydraulic power take-off at platform
- GRP platform
- Special paint colours

Other options available on request

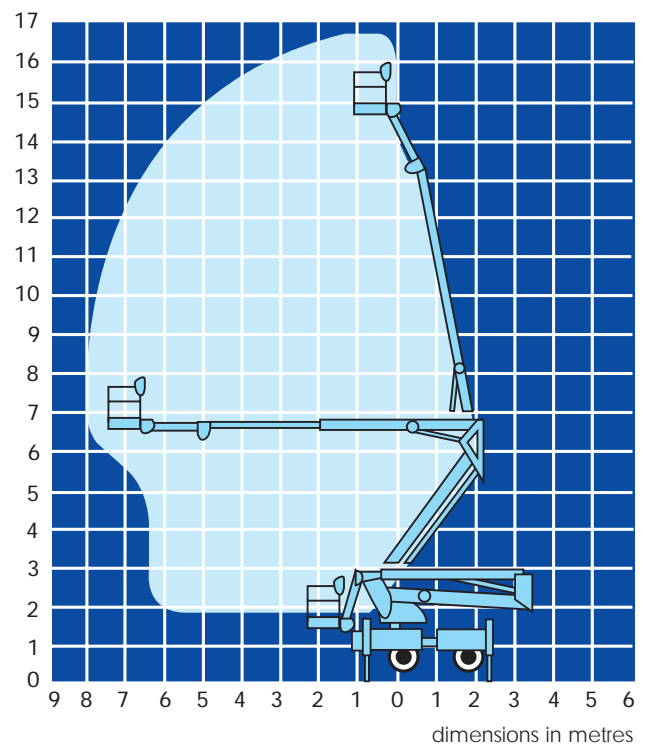

**CE** This product is available with the CE mark confirming compliance with all relevant European Machinery Directives

manufactured by  
**UpRight**  
POWERED ACCESS