

# TRAILER MOUNTED BOOM LIFT

# TL39

| DIMENSIONS                  | TL39        |
|-----------------------------|-------------|
| Max. working height         | 13.8m       |
| Max. platform height        | 11.8m       |
| Max. working outreach       | 6.4m        |
| Platform width (C)          | 1.15m       |
| Platform depth (D)          | 0.70m       |
| Outrigger footprint (A x B) | 4.0m x 3.6m |
| Towing width (E)            | 1.60m       |
| Towing length (F)           | 4.90m       |
| Stowed height (G)           | 2.20m       |
| Guardrail height            | 1.10m       |
| Toeboard height             | 0.15m       |

| PERFORMANCE                      |   |
|----------------------------------|---|
| Platform capacity (SWL)          | 215kg                                   |
| Turret rotation (non-continuous) | 540°                                    |
| Wheels                           | 185R14 C8                               |
| Controls                         | electric over hydraulic, variable speed |

| POWER        |               |
|--------------|---------------|
| Power source | 24V DC motor  |
| Battery      | 4 x 6V, 225Ah |

| WEIGHT                   |         |
|--------------------------|---------|
| Gross weight (DC)        | 1,694kg |
| Gross weight (Bi-energy) | 1,740kg |

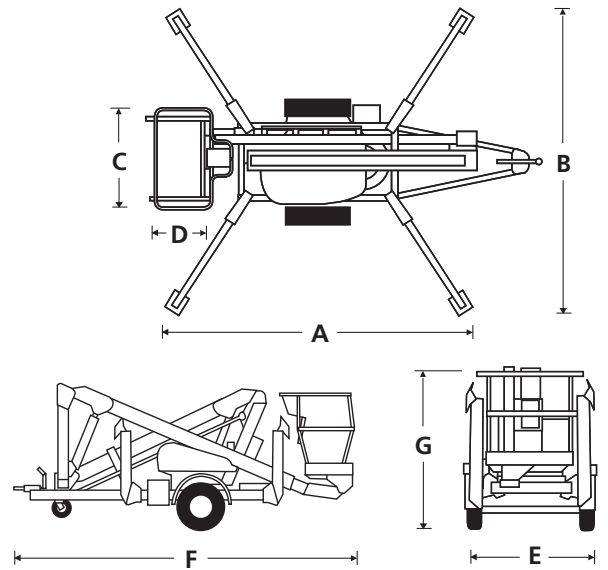

## STANDARD FEATURES

- Hydraulic outriggers
- Load sensing outrigger interlocks
- Articulating / telescopic boom configuration
- Electric controls at cage and base
- Power line to platform (no sockets)
- Automatic reverse and over-run braking
- Integrated automatic battery charger 110-230V
- CE approved

## OPTIONS

- Special paint colours
- Auto-level outriggers with LED indicators
- 180° manual platform rotator
- Platform work lights
- Air line to platform
- Flashing amber beacon
- Spare wheel
- Lifting lugs
- Alternative power sources:
  - Mains electric
  - Gasoline or diesel engine
  - Bi-Energy (DC & IC engine)

## WORKING ENVELOPE

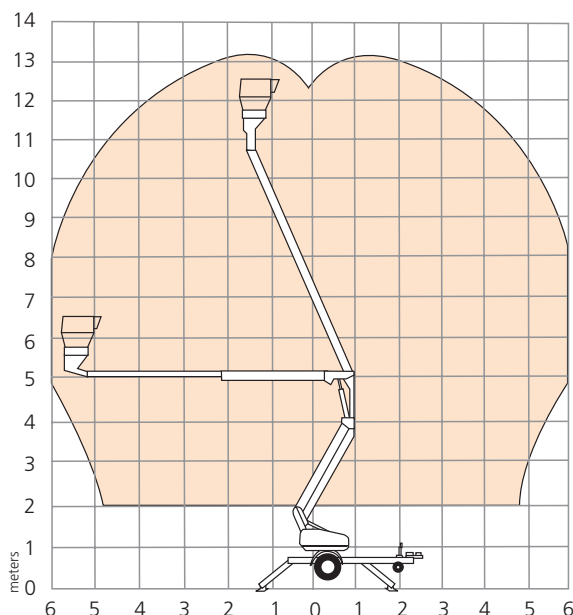

**snorkel** [www.snorkellifts.com](http://www.snorkellifts.com)

Vigo Centre, Birtley Road,  
Washington, Tyne & Wear,  
NE38 9DA, U.K.

t: +44 (0) 845 1550 057

e: sales@snorkellifts.com