

SPEED LEVEL

SL26SL/SL30SL

DIMENSIONS	SL26SL	SL30SL
Max. working height	10.0m	11.0m
Max. platform height (A)	8.0m	9.0m
Platform size (stowed)	1.72m x 3.66m	1.72m x 4.23m
Platform size (extended)	1.72m x 4.23m	n/a
Overall width (D)	2.13m	2.13m
Overall length (C)	3.79m	4.39m
Stowed height (B)	2.6m	2.6m
Min. height (guardrails folded)	1.1m	1.1m
Chassis ground clearance	320mm	320mm
Axle ground clearance	200mm	200mm

PERFORMANCE	SL26SL	SL30SL
Platform capacity (SWL)	680kg	590kg
Max. drive height	8.0m	9.0m
Max. drive speed (stowed)	5.2km/h	5.2km/h
Max. drive speed (elevated)	0.8km/h	0.8km/h
Raise/lower time	21/32 seconds	24/36 seconds
Gradeability	50%	50%
Max. levelling, front to rear	9°	9°
Max. levelling, side to side	13°	13°
Inside turning radius	3.9m	3.9m
Tyres	26 x 12.00 - 12 NHS Supa Terra-Grip, poly filled	
Controls	Proportional joystick	
Drive system	4 wheel drive with hydraulic motors and flow dividers	

POWER	SL26SL	SL30SL
Power source	Perkins diesel, water cooled engine	

WEIGHT	SL26SL	SL30SL
Gross weight	3,085kg	3,400kg

LEVELLING CAPABILITIES

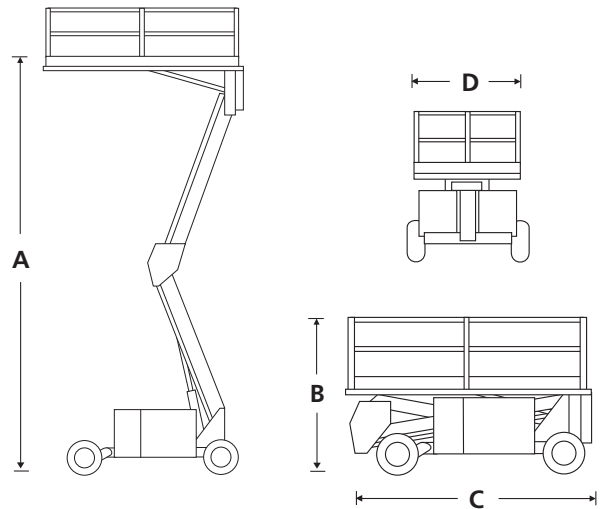
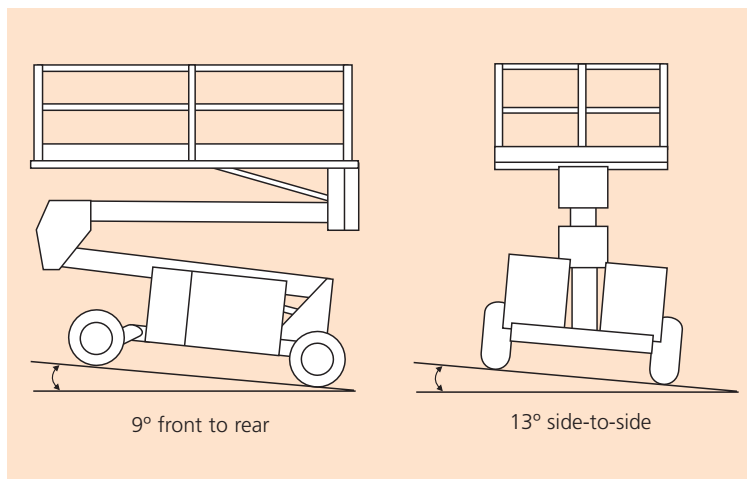

STANDARD FEATURES

- Diesel power
- Descent alarm
- Hour meter
- Speed level - automatic powered platform levelling
- Oscillating front axle
- Poly filled high grip tyres
- Dual multi-disc brakes
- One-hand, proportional controls
- Power line to platform (no sockets)
- Fold-down guardrails
- CE approved

OPTIONS

- Special paint colors
- All motion alarm
- Flashing amber beacon and horn
- Diesel exhaust scrubber
- Environmental green oil

snorkel

Vigo Centre, Birtley Road,
Washington, Tyne & Wear,
NE38 9DA, U.K.

t: +44 (0) 845 1550 057

e: sales@snorkellifts.com

www.snorkellifts.com