

Specifications

MODELS	GS™-2032		GS™-2632		GS™-3232	
	US	Metric	US	Metric	US	Metric
Working height maximum*	26 ft	8.10 m	32 ft	9.92 m	38 ft	11.75 m
A Platform height maximum	20 ft	6.10 m	26 ft	7.92 m	32 ft	9.75 m
B Platform length - outside	7 ft 5 in	2.26 m	7 ft 5 in	2.26 m	7 ft 5 in	2.26 m
extended	10 ft 5 in	3.18 m	10 ft 5 in	3.18 m	10 ft 5 in	3.18 m
Slide-out platform extension deck	3 ft	.91 m	3 ft	.91 m	3 ft	.91 m
C Platform width - outside	2 ft 8 in	.81 m	2 ft 8 in	.81 m	2 ft 8 in	.81 m
Guardrail height: fixed rails	3 ft 3 in	.99 m	—	—	—	—
fold down rails (CE)	3 ft 7 in	1.10 m	3 ft 7 in	1.10 m	3 ft 7 in	1.10 m
Toeboard height	6 in	.15 m	6 in	.15 m	6 in	.15 m
D Height - stowed						
fixed rails	6 ft 8 in	2.03 m	—	—	—	—
folding guardrails (CE)	7 ft	2.13 m	7 ft 5 in	2.26 m	8 ft	2.43 m
rails folded	5 ft 9 in	1.75 m	6 ft 3 in	1.91 m	6 ft 8 in	2.03 m
E Length - stowed	8 ft	2.44 m	8 ft	2.44 m	8 ft	2.43 m
Length - extended	10 ft 11 in	3.33 m	10 ft 11 in	3.33 m	10 ft 11 in	3.33 m
F Width	2 ft 8 in	.81 m	2 ft 8 in	.81 m	2 ft 8 in	.81 m
G Wheelbase	6 ft 1 in	1.85 m	6 ft 1 in	1.85 m	6 ft 1 in	1.85 m
H Ground clearance - center	3.5 in	.09 m	3.5 in	.09 m	3.5 in	.09 m
I - with pothole guards deployed	.75 in	.02 m	.75 in	.02 m	.75 in	.02 m

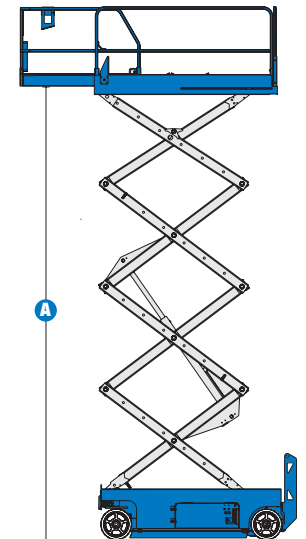
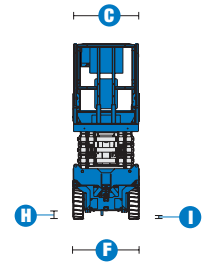
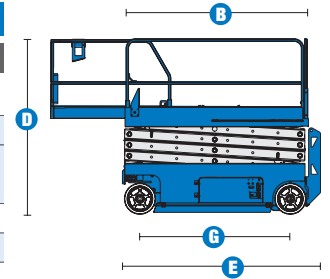

PRODUCTIVITY						
Lift capacity	800 lbs	363 kg	500 lbs	227 kg	500 lbs	227 kg
Extension deck capacity	250 lbs	113 kg	250 lbs	113 kg	250 lbs	113 kg
Drive height	full height		full height		22 ft	6.71 m
Drive speed - stowed	2.2 mph	3.5 km/h	2.2 mph	3.5 km/h	2.2 mph	3.5 km/h
Drive speed - raised	0.5 mph	0.8 km/h	0.5 mph	0.8 km/h	0.5 mph	0.8 km/h
Gradeability - stowed**	30%		25%		25%	
Maximum outrigger leveling: front to back	—		—		3°	
side to side	—		—		5°	
Turning radius - inside	zero	zero	zero	zero	zero	zero
Turning radius - outside	7 ft	2.13 m	7 ft	2.13 m	7 ft	2.13 m
Raise / lower speed	30 / 34 sec	30 / 34 sec	30 / 40 sec	30 / 40 sec	57 / 40 sec	57 / 40 sec
Controls	proportional		proportional		proportional	
Drive	dual front wheel		dual front wheel		dual front wheel	
Multiple disc brakes	dual rear wheel		dual rear wheel		dual rear wheel	
Tires - solid non-marking	15 x 5 x 11 in	38 x 13 x 28 cm	15 x 5 x 11 in	38 x 13 x 28 cm	15 x 5 x 11 in	38 x 13 x 28 cm

POWER						
Power source	24 V DC (four 6V 225 Ah batteries)		24 V DC (four 6V 225 Ah batteries)		24 V DC (four 6V 225 Ah batteries)	
Hydraulic system capacity	3.75 gal	14.2 L	3.75 gal	14.2 L	3.75 gal	14.2 L

WEIGHT***						
ANSI, CSA	3,574 lbs	1,621 kg	4,413 lbs	2,002 kg	5,185 lbs	2,352 kg
CE, AUS	4,024 lbs	1,825 kg	4,313 lbs	1,956 kg	5,185 lbs	2,352 kg

STANDARDS COMPLIANCE ANSI A92.6, CSA B354.2, CE Compliance, AS 1418.10, PB-10-611-03

* The metric equivalent of working height adds 2 m to platform height. U.S. adds 6 ft to platform height.
 ** Gradeability applies to driving on slopes. See operator's manual for details regarding slope ratings.
 *** Weight will vary depending on options and/or country standards.

Features

STANDARD FEATURES

MEASUREMENTS

GS™-2032

- 26 ft (8.10 m) working height
- Up to 800 lb (363 kg) lift capacity

GS™-2632

- 32 ft (9.92 m) working height
- Up to 500 lb (227 kg) lift capacity

GS™-3232

- 38 ft (11.75 m) working height
- Up to 500 lb (227 kg) lift capacity

PRODUCTIVITY

- 89 x 32 in (2.26 x .81 m) steel platform
- 36 in (.91 m) extension deck
- Fixed rail with chain entry gate (standard GS-2032)
- Folding rails with half-height swing gate (standard on all CE GS-2632, GS-3232)
- Automatic leveling outriggers (GS-3232 only)
- Dual front wheel drive
- Automatic battery charger
- Proportional lift and drive
- Onboard diagnostic system
- AC power to platform
- Manual platform lowering valve
- Emergency stop at both platform and ground controls
- Multiple disc brakes
- Brake release
- Solid non-marking tires
- Pothole guards
- Tilt level sensor with audible alarm
- Descent alarm
- Electronic horn
- Hour meter

POWER

- 24 V DC (four 6 V 225 Ah batteries)

OPTIONS & ACCESSORIES

PRODUCTIVITY

- Folding rails with half-height swing gate (GS-2032)
- Platform swing gate, half-height (GS-2032)
- Air line to platform
- Dual flashing beacons
- Motion package
- Platform work lights
- Ground controls cover
- Automotive horn
- Laser locator (GS-3232)

POWER

- Power Inverter
- Maintenance-free batteries
- EE rating



Genie United States

18340 NE 76th Street
P.O. Box 97030
Redmond, Washington 98073-9730

Telephone **(425) 881-1800**
Toll Free in USA/Canada **800-536-1800**
Fax (425) 883-3475

Genie Europe

The Maltings
Wharf Road
Grantham NG31 6BH
U.K.

Telephone **+44 (0)1476 584333**
Fax +44 (0)1476 584334

Email: infoeurope@genieind.com

Distributed By:

For further information, please contact your local distributor or the Genie Industries sales office listed. Product specifications are subject to change without notice or obligation. The photographs and drawings in this brochure are for illustrative purposes only. Refer to the appropriate Operator's Manual for instructions on the proper use of this equipment. Failure to follow the appropriate Operator's Manual when using our equipment or to otherwise act irresponsibly may result in serious injury or death. Prices and specifications subject to change without notice. The only warranty applicable is the standard written warranty applicable to the particular product and sale. Genie makes no other warranty, expressed or implied. Products and services listed may be trademarks, service marks or trade-names of Terex Corporation and/or its subsidiaries in the USA and other countries and all rights are reserved. Copyright © 2006 Genie Industries, Inc. "Genie" is a Registered Trademark of Genie Industries, Inc. in the USA and many other countries. Genie is a Terex Company.

GS32 3.5K 0307F Part No. 109378

www.genieindustries.com